

Receiver Bushings



Face Mount

Back Mount

Two styles of receiver bushings are available. Generally, the face mount receiver bushing is utilized in blind hole applications (Slip Fit). The back mount receiver bushing is used in through hole applications (Light Press Fit).

Note: Installed bushings should be approximately .012" below subplate surface.

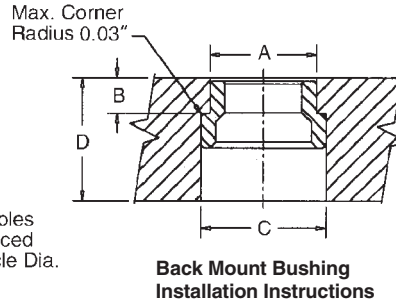
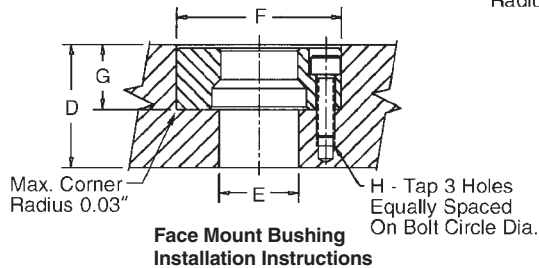
See reference below for installation of back mount style bushings.



Installation Dimensions

Face Mount

Shank Dia. (mm)	Face Mount Part Number	Actual O.D. +0.0000 -0.0004	Clearance Drill Diameter E	Bore +0.0005 -0.0000 F	Depth +0.002 -0.000 G	Tap Size & Depth ¹ H	Bolt Circle Diameter 3 PL Equally Space	Min. Subplate Thickness D
13	49506	1.3750	11/16	1.3750	0.469	8-32x5/16	0.984	3/4
16	49507	1.4370	13/16	1.4370	0.469	8-32x5/16	1.125	3/4
20	49501	1.6873	13/16	1.6873	0.637	10-32x3/8	1.362	1
25	49502	2.0623	1	2.0623	0.799	1/4-28x1/2	1.644	1-1/4
30	49503	2.2654	1 3/16	2.2654	0.871	1/4-28x3/4	1.876	1-3/8
35	49504	2.6873	1 9/16	2.6873	0.904	5/16-24x7/8	2.178	1-1/2
50	49505	3.4998	2 5/32	3.4998	1.239	3/8-24x1	2.916	2

¹Cap Screws Supplied with Face Mount Bushings.

Back Mount

Shank Dia. (mm)	Back Mount Part Number	Actual O.D. +0.0000 -0.0004 A	Depth +0.000 -0.002 B	C-Bore ±0.006 C	Min. Subplate Thickness D
13	49516	0.7870	.277	1.000	3/4
16	49517	0.8760	.285	1.155	3/4
20	49511	1.0950	.345	1.280	7/8
25	49512	1.3763	.416	1.593	1
30	49513	1.6264	.432	1.906	1-1/4
35	49514	1.8764	.493	2.155	1-5/16
50	49515	2.6269	.621	2.988	1-3/4

Liner Bushings for Fixture Plates



Locating repeatability will determine if one primary and one secondary or two primary liners are needed. With two primary liners, repeatability of ±0.0005" can be maintained if the two holes for receiver bushings are held to a centerline distance of ±0.0002" tolerance.

Note on Installation of Press Fit Liners & Back Mount Style Receiver Bushings:

To alleviate the possibility of binding the shank in the bore, the maximum interference fit between bore and bushing O.D. should not exceed .0005".

Liner Dimensions

Fixture Plate Thickness ±0.005	Shank Diameter (mm)	Primary Liner Part Number	Secondary Liner Part Number	Liner O.D. +0.0000 -0.0004
0.50	13	49705	49805	0.7518
0.75	13	49706	49806	0.7518
0.50	16	49707	49807	1.0018
0.75	16	49708	49808	1.0018
0.75	20	49701	49801	1.3772
1.00	20	49702	49802	1.3772
0.75	25	49711	49811	1.3772
1.00	25	49712	49812	1.3772
0.75	30	49721	49821	1.7523

Fixture Plate Thickness ±0.005	Shank Diameter (mm)	Primary Liner Part Number	Secondary Liner Part Number	Liner O.D. +0.0000 -0.0004
1.00	30	49722	49822	1.7523
0.75	35	49731	49831	1.7523
1.00	35	49732	49832	1.7523
1.50	35	49733	49833	1.7523
2.00	35	49734	49834	1.7523
0.75	50	49741	49841	2.5025
1.00	50	49742	49842	2.5025
1.50	50	49743	49843	2.5025
2.00	50	49744	49844	2.5025